

# **ASSEMBLY INSTRUCTIONS & PARTS MANUAL**

## **Closed ESP Shelving Models ESPC-1236, ESPC-1836, ESPC-2436, ESPC-6-1236, ESPC-6-1836, ESPC-6-2436**



RETAIN INSTRUCTIONS FOR FUTURE REFERENCE



ESPC-6-1236



ESPC-2436

**LOAD CAPACITIES  
PER SHELF LEVEL**  
250 lbs.

### **GENERAL SAFETY INFORMATION**

Some parts may have sharp edges. CARE must be taken when handling various pieces to avoid injury. For safety, wear a pair of work gloves when assembling or performing any maintenance on the units.

### **LIMITED WARRANTY**

Tennsco warrants goods purchased hereunder to be free of defects in materials and workmanship for a period of one (1) year from the date of shipment, hereunder. This warranty shall not apply in the event goods are damaged as a result of misuse, abuse, neglect, accident, improper application, modification or repair by persons not authorized by Seller, where goods are damaged during shipment, or where the date stamps on the goods have been defaced, modified or removed. UNLESS CONSIDERED UNENFORCEABLE OR UNLAWFUL UNDER APPLICABLE LAW:

- a. ALL IMPLIED WARRANTIES, INCLUDING BUT NOT LIMITED TO WARRANTIES OR MERCHANTABILITY AND FITNESS FOR A PARTICULAR PURPOSE ARE HEREBY EXCLUDED:
- b. BUYERS REMEDY, IF ANY, FOR ANY DEFECTIVE GOODS SHALL BE LIMITED TO A REFUND BY SELLER OR REPLACEMENT OF THE GOODS AT SELLER'S OPTION, AND SHALL IN NO EVENT INCLUDE DAMAGES OF ANY KIND, WHETHER INCIDENTAL, CONSEQUENTIAL OR OTHERWISE.

NO GOODS ACCEPTED FOR RETURN WITHOUT PRIOR APPROVAL. Seller shall have the right to inspect any goods claimed to be defective at Buyers place of business or require Buyer to return the goods to Seller for inspection on Seller's premises. Transportation charges covering returned goods will be borne by Seller only if such goods are proven to be defective, are covered by this warranty and are returned within the warranty period stated above.



**PROUDLY MADE IN THE U.S.A.**

Tennsco LLC., Dickson, TN 37056-1888 • (866) 446-8686

# ASSEMBLY OF CLOSED ESP SHELVING

Two people are recommended for assembly. Approximate assembly time: 10-15 minutes.

---

1. The reference numbers used throughout this sheet refer to the illustration on the back cover. This is to help you to identify the various parts as they are mentioned.
2. The unit back is shipped in two pieces. Place the two halves of the unit back (Ref. No. 1) flat on the ground and bolt together with  $1/4''$  - 20 nuts (Ref. No. 4) and  $1/4''$  - 20 x  $5/8''$  bolts (Ref. No. 5), spaced 16 or 17 inches apart. The top three holes should be left empty to leave room for the unit top.

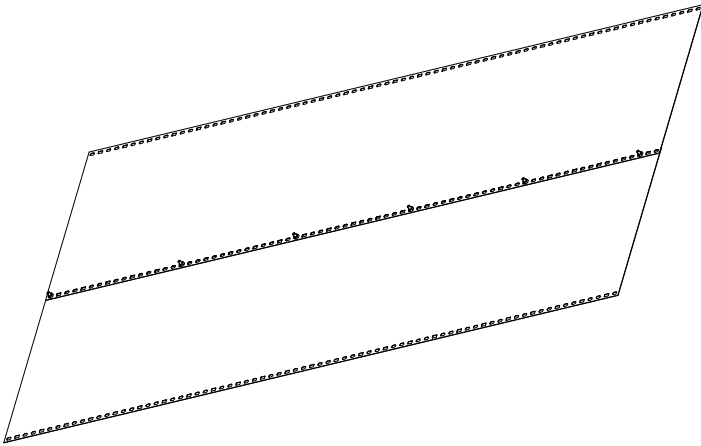

**NOTE: When bolting the unit together, leave the bolts slightly loose until the end of step 9, as binding may occur during shelf placement.**

3. Keep the back on a flat on the ground and attach one end panel (Ref. No. 3) to it by using  $1/4''$  - 20 nuts and  $1/4''$  - 20 x  $5/8''$  bolts and nuts spaced 16 to 17 inches apart as described in step 2. Once again, leave the top three holes empty to allow for the top shelf.

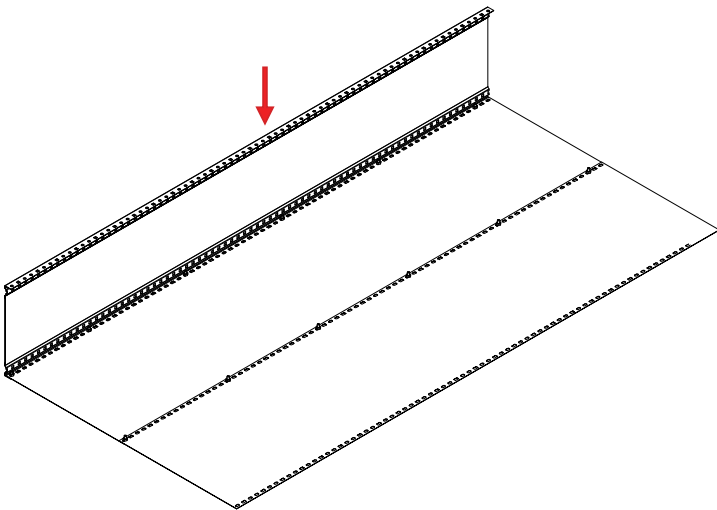

4. Attach the second end panel in the same manner as in step 3 on the opposite side of the back panels.

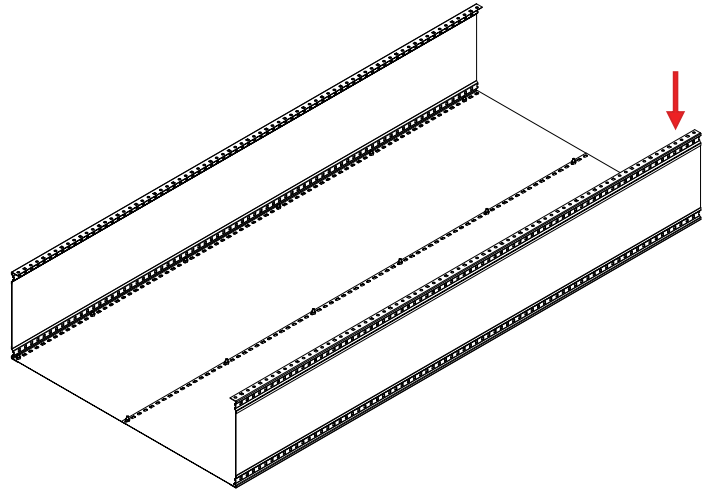

5. Insert four shelf clips (Ref. No. 6) into the top two slots of each side of both end panels.

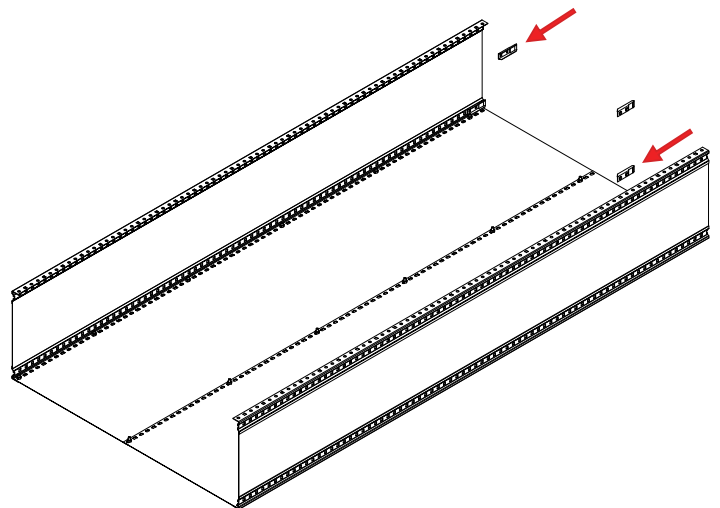

6. Place the top shelf (Ref. No. 2) over the four clips at the top of the unit. Be sure that the shelf is pushed securely into the clips.

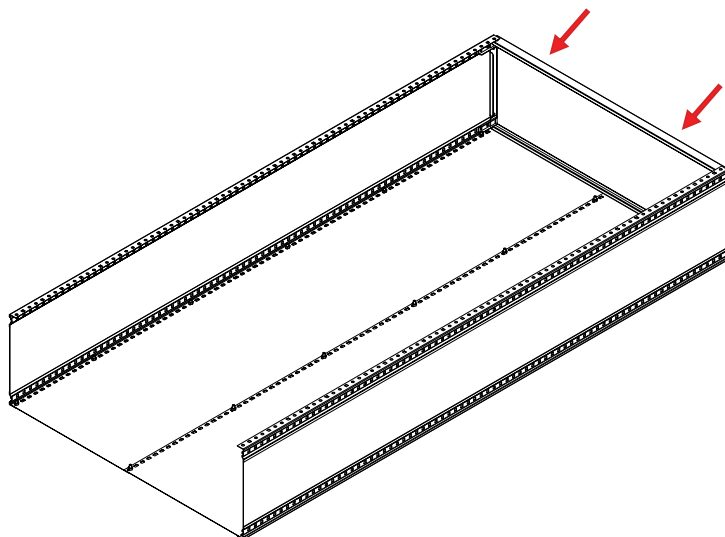

7. Insert four shelf clips into the bottom slots of the end panels in the same way that you did in the top of the unit in step 5.

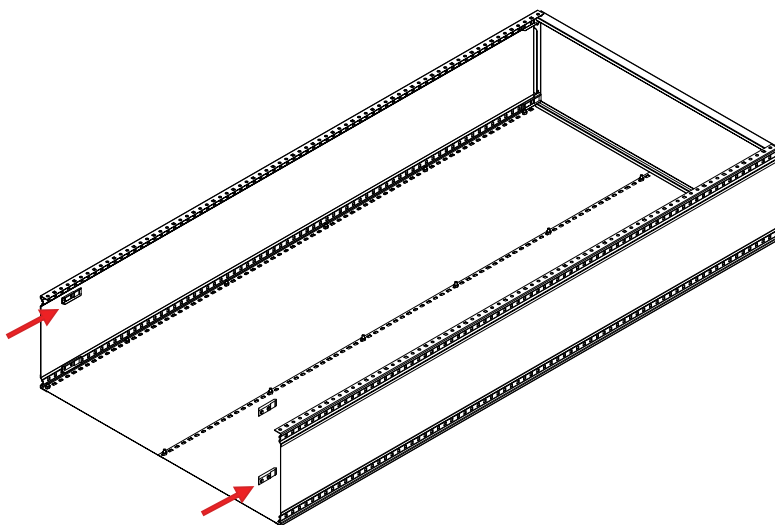

8. Place a shelf into the bottom four clips as in step 6.

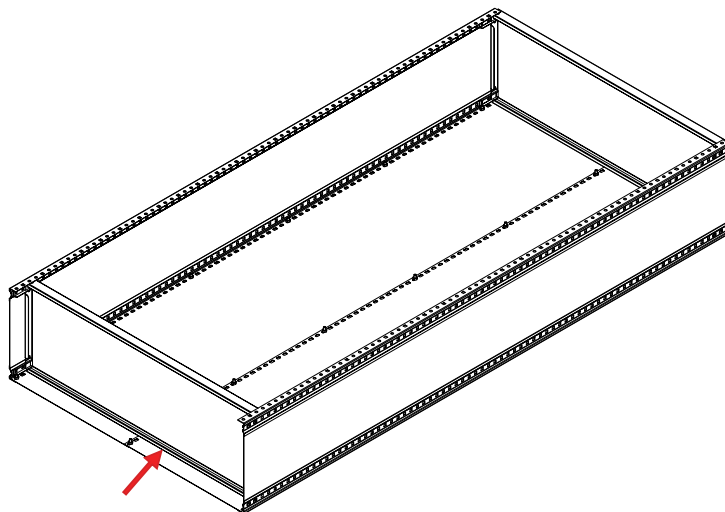

**NOTE:** Once the bottom shelf is in place, carefully lift the top end of the unit with the help of an associate, so that the shelving unit is standing upright.

9. Position the remaining shelf clips according to the desired shelf heights, and place the shelves over the clips. Keep in mind while placing the clips, that the post hole pattern of two round holes and then one square hole, repeated every 3 inches can greatly help in positioning the clips at the same level.

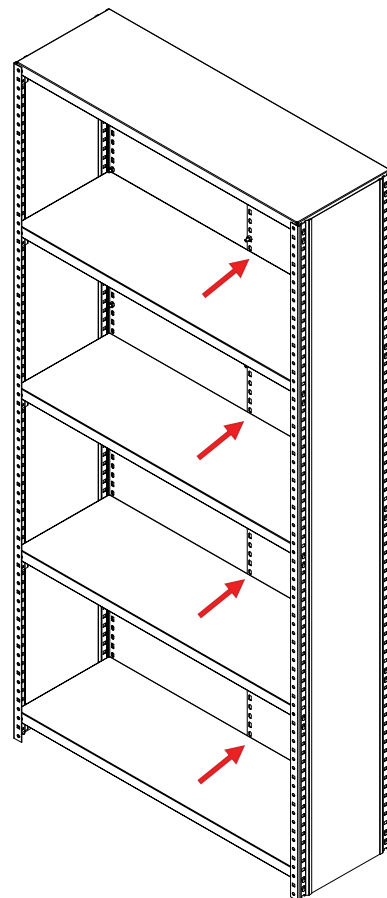

**NOTE:** Some shelves, depending upon their placement, could possibly require repositioning of some of the back and end panel bolts in order to insert the shelf. Once everything is correctly positioned tighten the bolts.

# REPLACEMENT PARTS

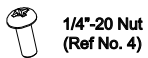
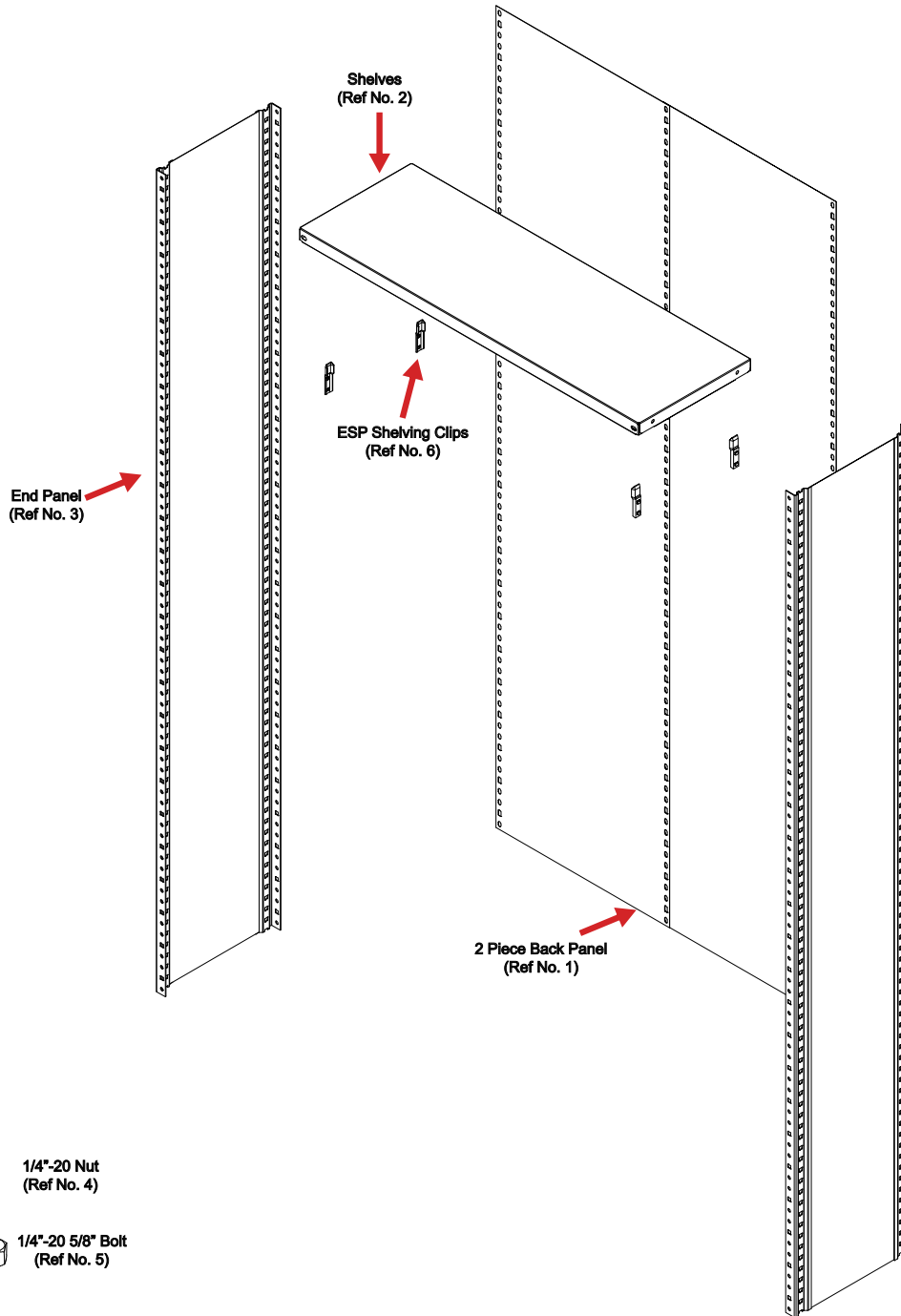

1/4"-20 Nut  
(Ref No. 4)



1/4"-20 5/8" Bolt  
(Ref No. 5)

REF. NO.	DESCRIPTION	PART NO.	36w x 12d		36w x 18d		36w x 24d	
			ESPC-1236	ESPC-6-1236	ESPC-1836	ESPC-6-1836	ESPC-2436	ESPC-6-2436
1	2 Piece Back Panels	ESPBP-3675	1	1	1	1	1	1
2	Shelves	ES-12	5	6				
		ES-18			5	6		
		ES-24					5	6
3	End Panels	ESPCU-1275	2	2				
		ESPCU-1875			2	2		
		ESPCU-2475					2	2
4	1/4"-20 Nuts	*	20	24	20	24	20	24
5	1/4"-20 5/8" Bolts	*	20	24	20	24	20	24
6	ESP Shelving Clips	ESPCLIP	20	24	20	24	20	24

NOTE: Additional hardware may be included for replacement purposes.

Tennsco makes every effort to ensure that all units ship complete with all parts and arrive undamaged. However, should your unit contain missing or damaged parts, please contact your purchase location.